

GEMÜ 687

Pneumatically operated diaphragm valve



Features

- Hermetic separation between medium and actuator
- CIP/SIP capable
- Wide range of adaptation options for add-on components and accessories
- Suitable for particulate and abrasive media
- Stainless steel body suitable for corrosive environments
- Wide range of adaptation options for add-on components and accessories

Description

The GEMÜ 687 2/2-way diaphragm valve has a low-maintenance plastic membrane actuator and is pneumatically operated. The valve has a metal distance piece. Normally Closed (NC), Normally Open (NO) and Double Acting (DA) control functions are available.

Technical specifications

- **Media temperature:** -10 to 100 °C
- **Sterilization temperature:** Max. 150 °C
- **Ambient temperature:** 0 to 60 °C
- **Operating pressure :** 0 to 10 bar
- **Nominal sizes:** DN 10 to 100
- **Body configurations:** 2/2-way body | T body | Tank valve body
- **Connection types:** Clamp | Flange | Spigot | Threaded connection
- **Connection standards:** ANSI | ASME | BS | DIN | EN | ISO | JIS | NPT | SMS
- **Body materials:** 1.4408, investment casting material | 1.4408, investment casting material, PFA lined | 1.4435 (316L), forged material | 1.4435, investment casting material | EN-GJS-400-18-LT (GGG 40.3), PFA lined | EN-GJS-400-18-LT (GGG 40.3), PP lined | EN-GJS-400-18-LT, hard rubber lined
- **Body lining:** Hard rubber | PFA | PP
- **Diaphragm materials:** EPDM | FKM | PTFE
- **Conformities:** 3A | Belgaqua | CRN | EAC | FDA | Functional safety | Oxygen | Reg. (EU) No. 10/2011 | Regulation (EC) No. 1935/2004 | TA Luft (German Clean Air Act) | USP

Technical data depends on the respective configuration



further information
webcode: GW-687



Product description

Construction



Item	Name	Materials
1	Position indicator	
2	Membrane actuator	PP, glass fibre reinforced
3	Control air connector	
4	Diaphragm	EPDM FKM PTFE/EPDM (one-piece, two-piece) PTFE/PVDF/EPDM (three-piece)
5	Valve body	EN-GJS-400-18-LT (GGG 40.3) PFA lined EN-GJS-400-18-LT (GGG 40.3) PP lined EN-GJS-400-18-LT (GGG 40.3) hard rubber lined 1.4408, investment casting 1.4408, PFA lined 1.4435 (F316L), forged body 1.4435 (BN2), forged body, $\Delta Fe < 0.5 \%$ 1.4435, investment casting 1.4539, forged body
6	CONEXO diaphragm RFID chip (see Conexo information)	
7	CONEXO body RFID chip (see Conexo information)	
8	CONEXO actuator RFID chip (see Conexo information)	

GEMÜ CONEXO

The interaction of valve components that are equipped with RFID chips and an associated IT infrastructure actively increase process reliability.



Thanks to serialization, every valve and every relevant valve component such as the body, actuator or diaphragm, and even automation components, can be clearly traced and read using the CONEXO pen RFID reader. The CONEXO app, which can be installed on mobile devices, not only facilitates and improves the "installation qualification" process, but also makes the maintenance process much more transparent and easier to document. The app actively guides the maintenance technician through the maintenance schedule and directly provides him with all the information assigned to the valve, such as test reports, testing documentation and maintenance histories. The CONEXO portal acts as a central element, helping to collect, manage and process all data.

For further information on GEMÜ CONEXO please visit:

www.gemu-group.com/conexo

Ordering

GEMÜ Conexo must be ordered separately with the ordering option "CONEXO".

Availabilities

Availability of grades of surface finish

Internal surface finishes for forged and block material bodies ¹⁾

Readings for Process Contact Surfaces	Mechanically polished ²⁾		Electropolished	
	Hygienic class DIN 11866	Code	Hygienic class DIN 11866	Code
Ra ≤ 0.80 µm	H3	1502	HE3	1503
Ra ≤ 0.60 µm	-	1507	-	1508
Ra ≤ 0.40 µm	H4	1536	HE4	1537
Ra ≤ 0.25 µm ³⁾	H5	1527	HE5	1516

Readings for Process Contact Surfaces according to ASME BPE 2016 ⁴⁾	Mechanically polished ²⁾		Electropolished	
	ASME BPE Surface Designation	Code	ASME BPE Surface Designation	Code
Ra Max. = 0.76 µm (30 µinch)	SF3	SF3	-	-
Ra Max. = 0.64 µm (25 µinch)	SF2	SF2	SF6	SF6
Ra Max. = 0.51 µm (20 µinch)	SF1	SF1	SF5	SF5
Ra Max. = 0.38 µm (15 µinch)	-	-	SF4	SF4

Internal surface finishes for investment cast bodies

Readings for Process Contact Surfaces	Mechanically polished ²⁾	
	Hygienic class DIN 11866	Code
Ra ≤ 6.30 µm	-	1500
Ra ≤ 0.80 µm	H3	1502
Ra ≤ 0.60 µm ⁵⁾	-	1507

Ra acc. to DIN EN ISO 4288 and ASME B46.1

- 1) Surface finishes of customized valve bodies may be limited in special cases.
- 2) Or any other finishing method that meets the Ra value (acc. to ASME BPE).
- 3) The smallest possible Ra finish for pipe connections with an internal pipe diameter < 6 mm is 0.38 µm.
- 4) When using these surfaces, the bodies are marked according to the specifications of ASME BPE.
The surfaces are only available for valve bodies which are made of materials (e.g. GEMÜ material codes 40, 41, F4, 44)) and use connections (e.g. GEMÜ connection codes 59, 80, 88) according to ASME BPE.
- 5) Not possible for GEMÜ connection code 59, DN 8 and GEMÜ connection code 0, DN 4.

Availability of valve bodies

Spigot

MG	DN	Connection type code ¹⁾																
		0	16	17	18	35	36	37	55	59	60	63	64	65				
		Material code ²⁾																
		40, 42, F4	40, 42, F4	C3	40, 42, F4	40, 42, F4	40, 42, F4	40, 42, F4	C3	40, 42, F4	40, 42, F4	C3	40, 42, F4	C3	40, 42, F4	40, 42, F4	40, 42, F4	40, 42, F4
10	10	-	X	X	X	X	-	X	-	-	X	-	X	X	X	X	-	X
	15	X	X	X	X	X	-	X	-	-	X	-	X	X	X	X	X	X
	20	-	-	-	-	-	-	-	-	-	X	X	X	-	-	-	-	-
25	15	X	X	X	X	X	-	X	-	-	-	-	-	X	X	X	X	X
	20	X	X	X	X	X	-	X	-	-	X	X	X	X	X	X	X	X
	25	X	X	X	X	X	X	X	X	X	-	X	X	X	X	X	X	X
40	32	X	X	X	X	X	X	X	-	X	-	-	-	X	X	X	X	X
	40	X	X	X	X	X	X	X	X	X	-	X	X	X	X	X	X	X
50	50	X	X	X	X	X	X	X	X	X	-	X	X	X	X	X	X	X
	65	-	-	-	-	-	X	-	-	X	-	-	X	-	-	-	-	-
80	65	-	-	-	X	-	X	X	-	X	-	-	X	-	X	X	X	X
	80	-	-	-	X	-	X	X	-	X	-	-	X	-	X	X	X	X
100	100	-	-	-	X	-	X	X	-	X	-	-	X	-	X	X	X	X

MG = diaphragm size, X = standard

1) Connection type

Code 0: Spigot DIN

Code 16: Spigot EN 10357 series B, formerly DIN 11850 series 1

Code 17: Spigot EN 10357 series A / DIN 11866 series A formerly DIN 11850 series 2

Code 18: Spigot DIN 11850 series 3

Code 35: Spigot JIS-G 3447

Code 36: Spigot JIS-G 3459 schedule 10s

Code 37: Spigot SMS 3008

Code 55: Spigot BS 4825, part 1

Code 59: Spigot ASME BPE/DIN 11866 series C

Code 60: Spigot ISO 1127/EN 10357 series C/DIN 11866 series B

Code 63: Spigot ANSI/ASME B36.19M schedule 10s

Code 64: Spigot ANSI/ASME B36.19M schedule 5s

Code 65: Spigot ANSI/ASME B36.19M schedule 40s

2) Valve body material

Code 40: 1.4435 (F316L), forged body

Code 42: 1.4435 (BN2), forged body, Δ Fe < 0.5%

Code C3: 1.4435, investment casting

Code F4: 1.4539, forged body

Threaded connection

MG	DN	Connection type code ¹⁾		
		1	31	6, 6K
		Material code ²⁾		
		37	37	40, 42
10	10	-	-	W
	12	X	-	-
	15	X	-	W
25	15	X	X	W
	20	X	X	W
	25	X	X	W
40	32	X	X	W
	40	X	X	W
50	50	X	X	W
80	65	-	-	W
	80	-	-	W

MG = diaphragm size, X = standard

W = welded assembly

1) **Connection type**

Code 1: Threaded socket DIN ISO 228

Code 31: NPT female thread

Code 6: Threaded spigot DIN 11851

Code 6K: Cone spigot and union nut DIN 11851

2) **Valve body material**

Code 37: 1.4408, investment casting

Code 40: 1.4435 (F316L), forged body

Code 42: 1.4435 (BN2), forged body, Δ Fe < 0.5%

Flange

MG	DN	Connection type code ¹⁾															
		8						38				39					
		Material code ²⁾															
		17	18	C3	39	40, 42	83	17	18 ³⁾	39	83	17	18	C3	39	40, 42	83
25	15	X	X	W	X	W	X	-	-	-	-	X	X	W	X	W	X
	20	X	X	W	X	W	X	X	X	X	X	X	X	W	X	W	X
	25	X	X	W	X	W	X	X	X	X	X	X	X	W	X	W	X
40	32	X	X	W	X	W	X	-	-	-	-	X	X	W	X	W	X
	40	X	X	W	X	W	X	X	X	X	X	X	X	W	X	W	X
50	50	X	X	W	X	W	X	X	X	X	X	X	X	W	X	W	X
80	65	-	-	-	-	W	-	-	-	-	-	-	-	-	-	W	-
	80	X	X	-	X	W	X	X	X	X	X	X	X	-	X	W	X
100	100	X	X	-	X	W	X	X	X	X	X	X	X	-	X	W	X

MG = diaphragm size, X = standard
W = welded assembly

1) **Connection type**

Code 8: Flange EN 1092, PN 16, form B, face-to-face dimension FTF EN 558 series 1, ISO 5752, basic series 1, length only for body configuration D

Code 38: Flange ANSI Class 150 RF, face-to-face dimension FTF MSS SP-88, length only for body configuration D

Code 39: Flange ANSI Class 125/150 RF, face-to-face dimension FTF EN 558 series 1, ISO 5752, basic series 1, length only for body configuration D

2) **Valve body material**

Code 17: EN-GJS-400-18-LT (GGG 40.3), PFA lined

Code 18: EN-GJS-400-18-LT (GGG 40.3), PP lined

Code 39: 1.4408, PFA lined

Code 40: 1.4435 (F316L), forged body

Code 42: 1.4435 (BN2), forged body, Δ Fe < 0.5%

Code 83: EN-GJS-400-18-LT (GGG 40.3), hard rubber lined

Code C3: 1.4435, investment casting

3) on request

Clamp

MG	DN	Connection type code ¹⁾				
		80, 8P	82	88, 8T	8A	8E
		Material code ²⁾				
		40, 42, F4				
10	10	-	K	-	K	-
	15	K	W	K	K	-
	20	K	-	K	-	-
25	15	-	W	-	K	-
	20	K	K	K	K	-
	25	K	K	K	K	K
40	32	-	W	-	K	K
	40	K	W	K	K	K
50	50	K	W	K	K	K
	65	W	-	W	-	W
80	65	K	K	K	K	K
	80	K	W	K	W	K
100	100	W	W	W	W	W

MG = diaphragm size

K = connections completely machined (not welded)

W = welded assembly

1) Connection type

Code 80: Clamp ASME BPE, face-to-face dimension FTF ASME BPE, length only for body configuration D

Code 82: Clamp DIN 32676 series B, face-to-face dimension FTF EN 558 series 7, length only for body configuration D

Code 88: Clamp ASME BPE, for pipe ASME BPE, face-to-face dimension FTF EN 558 series 7, length only for body configuration D

Code 8A: Clamp DIN 32676 series A, face-to-face dimension FTF acc. to EN 558 series 7, length only for body configuration D

Code 8E: Clamp ISO 2852 for pipe ISO 2037, clamp SMS 3017 for pipe SMS 3008 face-to-face dimension FTF EN 558 series 7, length only for body configuration D

Code 8P: Clamp DIN 32676 series C, face-to-face dimension FTF ASME BPE, length only for body configuration D

Code 8T: Clamp DIN 32676 series C, face-to-face dimension FTF EN 558 series 7, length only for body configuration D

2) Valve body material

Code 40: 1.4435 (F316L), forged body

Code 42: 1.4435 (BN2), forged body, Δ Fe < 0.5%

Code F4: 1.4539, forged body

Availability of product conformity

	Diaphragm material code ¹⁾	Body material code ²⁾
Food		
3A	54, 5M	-
Drinking water		
Belgaqua (B)	28	37

1) Diaphragm material

Code 28: EPDM

Code 54: PTFE/EPDM one-piece

Code 5M: PTFE/EPDM two-piece

2) Valve body material

Code 37: 1.4408, investment casting

Order data

The order data provide an overview of standard configurations.

Please check the availability before ordering. Other configurations available on request.

Order codes

1 Type	Code
Diaphragm valve, pneumatically operated, plastic actuator, stainless steel distance piece	687

2 DN	Code
DN 10	10
DN 12	12
DN 15	15
DN 20	20
DN 25	25
DN 32	32
DN 40	40
DN 50	50
DN 65	65
DN 80	80
DN 100	100

3 Body configuration	Code
Tank bottom valve body	B
Body configuration code B: Dimensions and designs on request	
2/2-way body	D
T body	T
Body configuration code T: Dimensions on request	

4 Connection type	Code
Spigot	
Spigot DIN	0
Spigot EN 10357 series B, formerly DIN 11850 series 1	16
Spigot EN 10357 series A / DIN 11866 series A formerly DIN 11850 series 2	17
Spigot DIN 11850 series 3	18
Spigot JIS-G 3447	35
Spigot JIS-G 3459 schedule 10s	36
Spigot SMS 3008	37
Spigot BS 4825, part 1	55
Spigot ASME BPE/DIN 11866 series C	59
Spigot ISO 1127/EN 10357 series C/DIN 11866 series B	60
Spigot ANSI/ASME B36.19M schedule 10s	63
Spigot ANSI/ASME B36.19M schedule 5s	64
Spigot ANSI/ASME B36.19M schedule 40s	65
Threaded connection	
Threaded socket DIN ISO 228	1
NPT female thread	31
Threaded spigot DIN 11851	6
Cone spigot and union nut DIN 11851	6K

4 Connection type	Code
Flange	
Flange EN 1092, PN 16, form B, face-to-face dimension FTF EN 558 series 1, ISO 5752, basic series 1, length only for body configuration D	8
Flange ANSI Class 150 RF, face-to-face dimension FTF MSS SP-88, length only for body configuration D	38
Flange ANSI Class 125/150 RF, face-to-face dimension FTF EN 558 series 1, ISO 5752, basic series 1, length only for body configuration D	39
Clamp	
Clamp ASME BPE, face-to-face dimension FTF ASME BPE, length only for body configuration D	80
Clamp DIN 32676 series B, face-to-face dimension FTF EN 558 series 7, length only for body configuration D	82
Clamp ASME BPE, for pipe ASME BPE, face-to-face dimension FTF EN 558 series 7, length only for body configuration D	88
Clamp DIN 32676 series A, face-to-face dimension FTF acc. to EN 558 series 7, length only for body configuration D	8A
Clamp ISO 2852 for pipe ISO 2037, clamp SMS 3017 for pipe SMS 3008 face-to-face dimension FTF EN 558 series 7, length only for body configuration D	8E
Clamp DIN 32676 series C, face-to-face dimension FTF ASME BPE, length only for body configuration D	8P
Clamp DIN 32676 series C, face-to-face dimension FTF EN 558 series 7, length only for body configuration D	8T

5 Valve body material	Code
SG iron material	
EN-GJS-400-18-LT (GGG 40.3), PFA lined	17
EN-GJS-400-18-LT (GGG 40.3), PP lined	18
EN-GJS-400-18-LT (GGG 40.3), hard rubber lined	83
Investment casting material	
1.4408, investment casting	37
1.4408, PFA lined	39
1.4435, investment casting	C3
Forged material	
1.4435 (F316L), forged body	40
1.4435 (BN2), forged body, $\Delta Fe < 0.5\%$	42

Order data

5 Valve body material	Code
1.4539, forged body	F4

6 Diaphragm material	Code
Elastomer	
FKM	4
EPDM	13
EPDM	17
EPDM	19
EPDM	28
EPDM	29
EPDM	36
PTFE	
PTFE/EPDM one-piece	54
PTFE/EPDM two-piece	5M
PTFE/PVDF/EPDM three-piece	71
Note: The PTFE/EPDM diaphragm (code 5M) is available from diaphragm size 25.	
Note: The PTFE/PVDF/EPDM diaphragm (code 71) can only be combined with PFA lined valve bodies.	

7 Control function	Code
Normally closed (NC)	1
Normally open (NO)	2
Double acting (DA)	3

8 Actuator version	Code
Actuator size B/N	B/N
Actuator size F/M	F/M
Actuator size F/N	F/N
Actuator size H/M	H/M
Actuator size H/N	H/N
Actuator size J/M	J/M
Actuator size J/N	J/N
Actuator size 4/N	4/N
Actuator size 4RN	4RN
Actuator size 5/N	5/N
Actuator size 5RN	5RN
Actuator size 6A	6A
Actuator size 6A2	6A2
Actuator size 7A	7A
Actuator size 7A3	7A3

9 Surface	Code
Ra ≤ 6.3 µm (250 µin.) for media wetted surfaces, mechanically polished internal	1500
Ra ≤ 0.8 µm (30 µin.) for media wetted surfaces, in accordance with DIN 11866 H3, mechanically polished internal	1502
Ra ≤ 0.8 µm (30 µin.) for media wetted surfaces, in accordance with DIN 11866 HE3, electropolished internal/external	1503
Ra ≤ 0.6 µm (25 µin.) for media wetted surfaces, mechanically polished internal	1507
Ra ≤ 0.6 µm (25 µin.) for media wetted surfaces, electropolished internal/external	1508

9 Surface	Code
Ra ≤ 0.25 µm (10 µin.) for media wetted surfaces *), in accordance with DIN 11866 HE5, electropolished internal/external, *) for inner pipe diameters < 6 mm, in the spigot Ra ≤ 0.38 µm	1516
Ra ≤ 0.25 µm (10 µin.) for media wetted surfaces *), in accordance with DIN 11866 H5, mechanically polished internal, *) for inner pipe diameters < 6 mm, in the spigot Ra ≤ 0.38 µm	1527
Ra ≤ 0.4 µm (15 µin.) for media wetted surfaces, in accordance with DIN 11866 H4, mechanically polished internal	1536
Ra ≤ 0.4 µm (15 µin.) for media wetted surfaces, in accordance with DIN 11866 HE4, electropolished internal/external	1537
Ra max. 0.51 µm (20 µin.) for media wetted surfaces, in accordance with ASME BPE SF1, mechanically polished internal	SF1
Ra max. 0.64 µm (25 µin.) for media wetted surfaces, in accordance with ASME BPE SF2, mechanically polished internal	SF2
Ra max. 0.76 µm (30 µin.) for media wetted surfaces, in accordance with ASME BPE SF3, mechanically polished internal	SF3
Ra max. 0.38 µm (15 µin.) for media wetted surfaces, in accordance with ASME BPE SF4, electropolished internal/external	SF4
Ra max. 0.51 µm (20 µin.) for media wetted surfaces, in accordance with ASME BPE SF5, electropolished internal/external	SF5
Ra max. 0.64 µm (25 µin.) for media wetted surfaces, in accordance with ASME BPE SF6, electropolished internal/external	SF6

10 Special version	Code
Without	
BELGAQUA certification	B
Special version for 3A	M
Special version for oxygen, maximum medium temperature: 60 °C	S

11 CONEXO	Code
Without	
Integrated RFID chip for electronic identification and traceability	C

Order example

Ordering option	Code	Description
1 Type	687	Diaphragm valve, pneumatically operated, plastic actuator, stainless steel distance piece
2 DN	25	DN 25
3 Body configuration	D	2/2-way body
4 Connection type	60	Spigot ISO 1127/EN 10357 series C/DIN 11866 series B
5 Valve body material	40	1.4435 (F316L), forged body
6 Diaphragm material	5M	PTFE/EPDM two-piece
7 Control function	1	Normally closed (NC)
8 Actuator version	F/N	Actuator size F/N
9 Surface	1503	Ra ≤ 0.8 µm (30 µin.) for media wetted surfaces, in accordance with DIN 11866 HE3, electropolished internal/external
10 Special version	M	Special version for 3A
11 CONEXO		Without

Technical data

Medium

Working medium: Corrosive, inert, gaseous and liquid media which have no negative impact on the physical and chemical properties of the body and diaphragm material.
For special oxygen version (code S):only gaseous oxygen

Control medium: Inert gases

Temperature

Media temperature:

Diaphragm material	Standard	Special version for oxygen
EPDM (code 3A/13)	-10 – 100 °C	0 – 60 °C
FKM (code 4/4A)	-10 – 90 °C	-
EPDM (code 17)	-10 – 100 °C	-
EPDM (code 19)	-10 – 100 °C	0 – 60 °C
EPDM (code 28)	-10 – 85 °C	-
EPDM (code 29)	-10 – 100 °C	-
EPDM (code 36)	-10 – 100 °C	-
PTFE/EPDM (code 54)	-10 – 100 °C	0 – 60 °C
PTFE/PVDF/EPDM (code 71)	-10 – 100 °C	-
PTFE/EPDM (code 5M)	-10 – 100 °C	0 – 60 °C

Sterilization temperature:

EPDM (code 3A/13)	max. 150 °C, max. 60 min per cycle
FKM (code 4/4A)	not applicable
EPDM (code 17)	max. 150 °C, max. 180 min per cycle
EPDM (code 19)	max. 150 °C, max. 180 min per cycle
EPDM (code 28)	not applicable
EPDM (code 29)	not applicable
EPDM (code 36)	max. 150 °C, max. 60 min per cycle
PTFE/EPDM (code 54)	max. 150 °C, permanent temperature per cycle
PTFE/PVDF/EPDM (code 71)	not applicable
PTFE/EPDM (code 5M)	max. 150 °C, permanent temperature per cycle

The sterilization temperature is only valid for steam (saturated steam) or superheated water.

If the sterilization temperatures listed above are applied to the EPDM diaphragms for longer periods of time, the service life of the diaphragms will be reduced. In these cases, maintenance cycles must be adapted accordingly.

PTFE diaphragms can also be used as moisture barriers; however, this will reduce their service life. This also applies to PTFE diaphragms exposed to high temperature fluctuations. The maintenance cycles must be adapted accordingly. GEMÜ 555 and 505 globe valves are particularly suitable for use in the area of steam generation and distribution. The following valve arrangement for interfaces between steam pipes and process pipes has proven itself over time: A globe valve for shutting off steam pipes and a diaphragm valve as an interface to the process pipes.

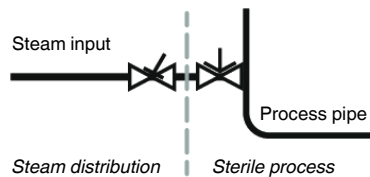

Ambient temperature: 0 – 60 °C

Control medium temperature: 0 – 40 °C

Storage temperature: 0 – 40 °C

Pressure

Operating pressure:

MG	DN	Actuator version code	Control function 1		Control function 2 + 3	
			Diaphragm material			
			EPDM/FKM	PTFE	EPDM/FKM	PTFE
10	10, 15, 20	B/N	0 - 10	0 - 6	0 - 6	0 - 6
25	15, 20, 25	F/M	0 - 6	0 - 6	-	-
		F/N	0 - 10	0 - 10	0 - 10	0 - 10
40	32, 40	H/M	0 - 6	0 - 6	-	-
		H/N	0 - 10	0 - 10	0 - 10	0 - 10
50	50, 65	J/M	0 - 6	0 - 6	-	-
		J/N	0 - 10	0 - 10	0 - 10	0 - 10
80	65, 80	4/N	0 - 8	0 - 5	0 - 8	0 - 6
		6A	-	-	-	0 - 10
		6A2	-	0 - 10	-	-
100	100	5/N	0 - 6	0 - 4	0 - 6	0 - 4
		7A	-	-	-	0 - 10
		7A3	-	0 - 10	-	-

MG = diaphragm size

All pressures are gauge pressures. Operating pressure values were determined with static operating pressure applied on one side of a closed valve. Sealing at the valve seat and atmospheric sealing is ensured for the given values.

Information on operating pressures applied on both sides and for high purity media on request.

Pressure rating: PN 16

Leakage rate: Leakage rate A to P11/P12 EN 12266-1

Control pressure:

MG	DN	Actuator version code	Control function 1	Control function 2	Control function 3
10	10, 15, 20	B/N	3.5 - 7.0	max. 6.0	max. 5.0
25	15, 20, 25	F/M	3.8 - 6.0	-	-
		F/N	5.5 - 7.0	max. 5.5	max. 5.5
40	32, 40	H/M	3.8 - 6.0	-	-
		H/N	5.5 - 7.0	max. 5.5	max. 5.5
50	50, 65	J/M	3.8 - 6.0	-	-
		J/N	5.5 - 7.0	max. 5.0	max. 5.0
80	65, 80	4/N	5.5 - 7.0	max. 5.0	max. 4.5
		6A	-	max. 3.0	max. 3.0
		6A2	4.0 - 7.0	-	-
100	100	5/N	5.5 - 7.0	max. 5.0	max. 4.5
		7A	-	max. 3.5	max. 3.5
		7A3	4.5 - 7.0	-	-

MG = diaphragm size

All pressures are gauge pressures.

Control pressure:

Control pressure/operating pressure diagram – Control function 2 and 3

PTFE diaphragm

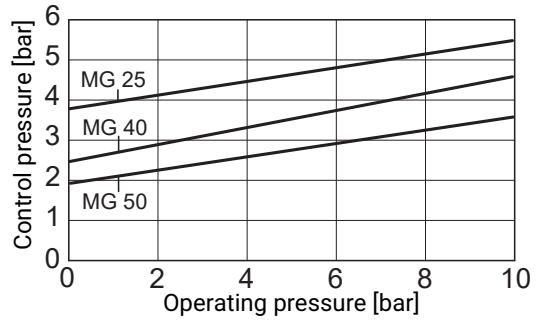
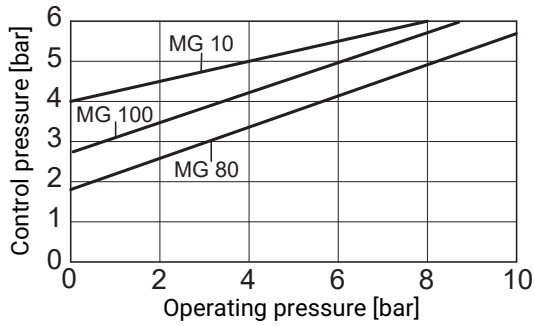

Elastomer diaphragm

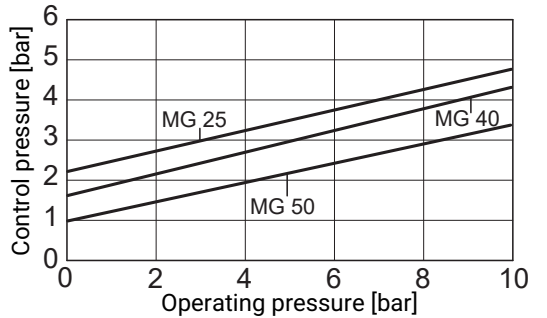
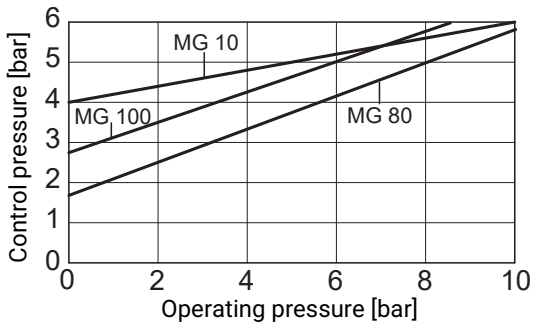

The control pressure depending on the prevailing operating pressure, as shown in the diagram, is intended as a guide for operating the system with low wear on the diaphragm.

Filling volume:

Actuator version (code)	Control function 1	Control function 2
B/N	0.03	0.02
F/M	0.20	-
F/N	0.20	0.16
H/M	0.42	-
H/N	0.42	0.40
J/M	0.79	-
J/N	0.79	0.69
4/N	2.30	1.87
5/N	2.30	2.00

Actuator volume in dm³

C.f. 3 = for filling volume in open position see c.f. 1, for filling volume in closed position see c.f. 2

Kv values:

MG	DN	Connection type code								
		0	16	17	18	37	59	60	1	31
10	10	-	2.4	2.4	2.4	-	2.2	3.3	-	-
	12	-	-	-	-	-	-	-	3.2	-
	15	3.3	3.8	3.8	3.8	-	2.2	4.0	3.4	-
	20	-	-	-	-	-	3.8	-	-	-
25	15	4.1	4.7	4.7	4.7	-	-	7.4	6.5	6.5
	20	6.3	7.0	7.0	7.0	-	4.4	13.2	10.0	10.0
	25	13.9	15.0	15.0	15.0	12.6	12.2	16.2	14.0	14.0
40	32	25.3	27.0	27.0	27.0	26.2	-	30.0	26.0	26.0
	40	29.3	30.9	30.9	30.9	30.2	29.5	32.8	33.0	33.0
50	50	46.5	48.4	48.4	48.4	51.7	50.6	55.2	60.0	60.0
	65	-	-	-	-	62.2	61.8	-	-	-
80	65	-	-	77.0	-	68.5	68.5	96.0	-	-
	80	-	-	111.0	-	80.0	87.0	111.0	-	-
100	100	-	-	194.0	-	173.0	188.0	214.0	-	-

MG = diaphragm size

Kv values in m³/h

Kv values determined in accordance with DIN EN 60534 standard, inlet pressure 5 bar, Δp 1 bar, stainless steel valve body and soft elastomer diaphragm. The Kv values for other product configurations (e.g. other diaphragm or body materials) may differ. In general, all diaphragms are subject to the influences of pressure, temperature, the process and their tightening torques. Therefore the Kv values may exceed the tolerance limits of the standard.

The Kv value curve (Kv value dependent on valve stroke) can vary depending on the diaphragm material and duration of use.

Product conformity

Machinery Directive: 2006/42/EC

Pressure Equipment Directive: 2014/68/EU

Food: Regulation (EC) No. 1935/2006
 Regulation (EC) No. 10/2011*
 FDA*
 USP* Class VI

Drinking water: Belgaqua*
 * depending on version and / or operating parameters

SIL:

Product description:	GEMÜ diaphragm valve 687
Type of valve:	A
Safety function:	Due to the safety function, the diaphragm valve is placed in the closed position (with control function 1) or in the open position (with control function 2).
HFT (Hardware Fault Tolerance):	0
MTTR (Mean Time To Restoration):	24 hours

Mechanical data

Weight:

Actuator

MG	DN	Actuator version (code)	Control function 1	Control function 2 and 3
10	10, 15, 20	B/N	0.53	-
25	15, 20, 25	F/M, F/N	2.2	1.7
40	32, 40	H/M, H/N	4.7	3.1
50	50, 65	J/M, J/N	6.9	5.2
80	65, 80	4/N	15.0	-
	65, 80	6A	-	-
	65, 80	6A2	52.0	-
100	100	5/N	16.1	-
	100	7A	-	-
	100	7A3	63.0	-

Weights in kg
 MG = diaphragm size

Weight:

Body

MG	DN	Spigot	Threaded socket	Threaded spigot, cone spigot	Flange	Clamp
		Connection type code				
		0, 16, 17, 18, 35, 36, 37, 55, 59, 60, 63, 64, 65	1, 31	6, 6K	8, 38, 39	80, 82, 88, 8A, 8E, 8P, 8T
10	10	0.30	-	0.33	-	0.30
	12	-	0.17	-	-	-
	15	0.30	0.26	0.35	-	0.43
	20	-	-	-	-	0.43
25	15	0.62	0.32	0.71	1.50	0.75
	20	0.58	0.34	0.78	2.20	0.71
	25	0.55	0.39	0.79	2.80	0.63
40	32	1.45	0.88	1.66	3.40	1.62
	40	1.32	0.93	1.62	4.50	1.50
50	50	2.25	1.56	2.70	6.30	2.50
	65	2.20	-	-	10.30	2.30
80	65	8.60	-	9.22	10.20	8.90
	80	8.00	-	9.20	13.80	8.50
100	100	24.10	-	-	20.80	24.80

Weights in kg
MG = diaphragm size

Dimensions

Actuator dimensions

Actuator - Control function 1

Control function 1 - Diaphragm size 10
Actuator size B/N

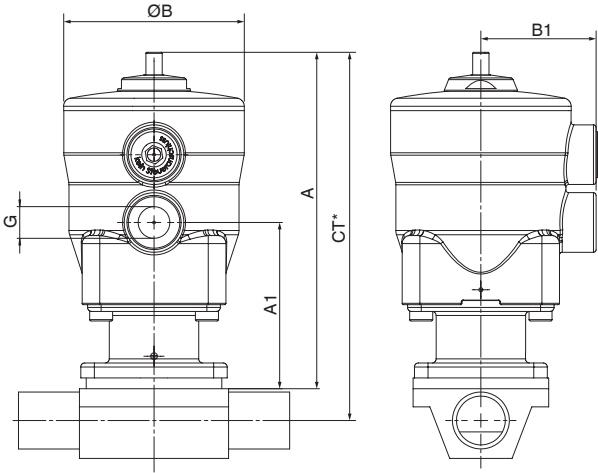

Control function 1 - Diaphragm size 25 - 50
Actuator size F/M, F/N, H/M, H/N, J/M, J/N

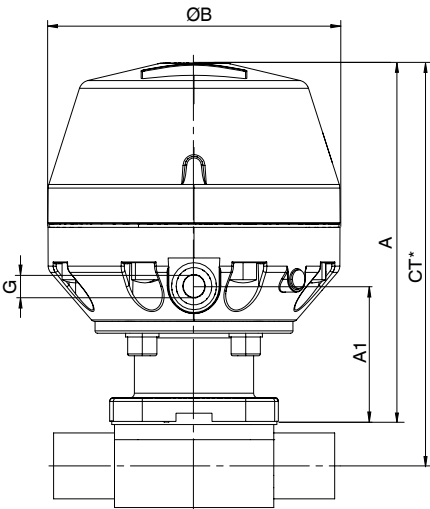

Control function 1 - Diaphragm size 80, 100
Actuator size 4/N, 6A2, 5/N, 7A3

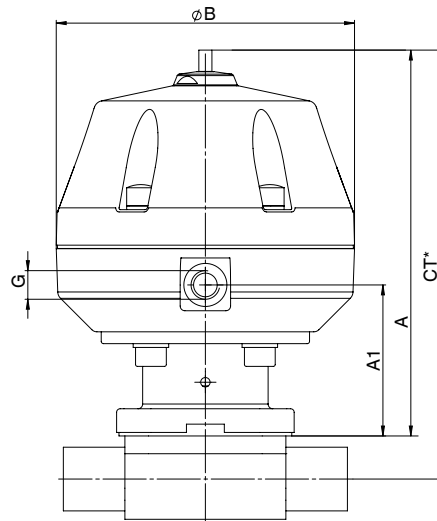

MG	Actuator size	ø B	A	A1	B1	G
10	B/N	67.0	125.0	62.0	44.0	G 1/4
25	F/M, F/N	130.0	170.0	59.0	-	G 1/4
40	H/M, H/N	171.0	208.0	75.0	-	G 1/4
50	J/M, J/N	211.0	244.0	90.0	-	G 1/4
80	4/N	259.0	368.0	173.0	-	G 1/4
	6A2	360.0	475.0	158.0	-	G 1/4
100	5/N	259.0	372.0	169.0	-	G 1/4
	7A3	360.0	477.0	154.0	-	G 1/4

Dimensions in mm

MG = diaphragm size

* CT = A + H1 (see body dimensions)

Actuator - Control function 2 and 3

Control function 2 + 3 - Diaphragm size 10
Actuator size B/N

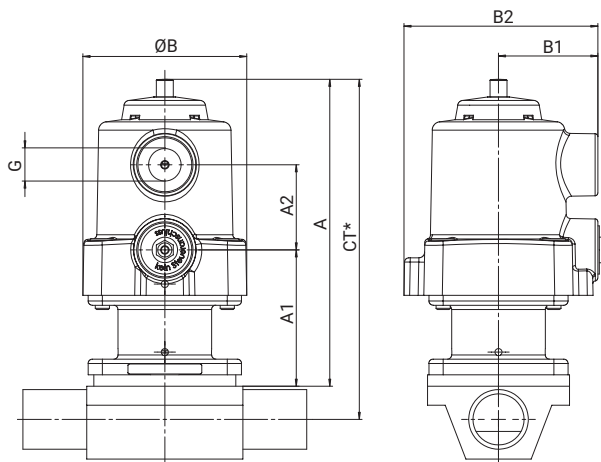

Control function 2 + 3 - Diaphragm size 25 - 50
Actuator size F/M, F/N, H/M, H/N, J/M, J/N

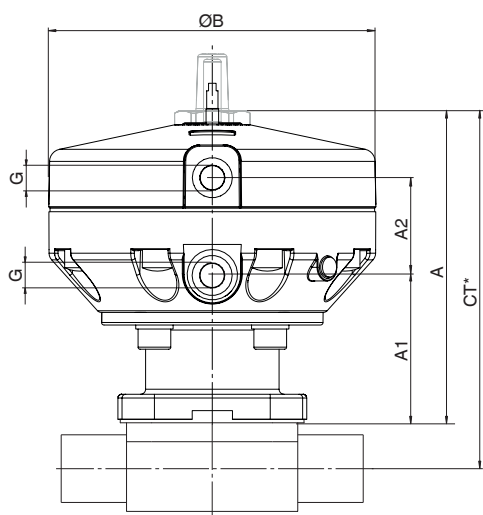

Control function 2 + 3 - Diaphragm size 100
Actuator size 4/N, 6A2, 5/N, 7A3

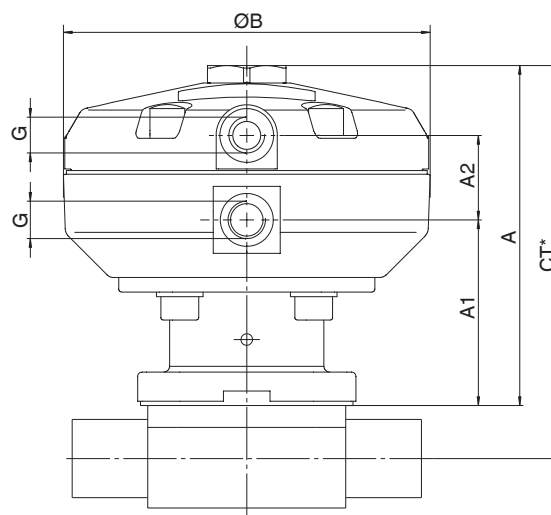

MG	Actuator size	ø B	A	A1	A2	B1	B2	G
10	B/N	57.0	110.0	49.0	30.0	35.0	68.0	G 1/4
25	F/M, F/N	130.0	147.0	59.0	39.0	-	-	G 1/4
40	H/M, H/N	171.0	173.0	75.0	42.0	-	-	G 1/4
50	J/M, J/N	211.0	206.0	90.0	47.0	-	-	G 1/4
80	4/N	258.0	282.0	170.0	45.0	-	-	G 1/4
	6A	360.0	323.0	158.0	110.0	-	-	G 1/4
100	5/N	258.0	278.0	165.0	45.0	-	-	G 1/4
	7A	360.0	319.0	154.0	110.0	-	-	G 1/4

Dimensions in mm

MG = diaphragm size

* CT = A + H1 (see body dimensions)

Body dimensions

Spigot DIN/EN/ISO (code 0, 16, 17, 18, 60)

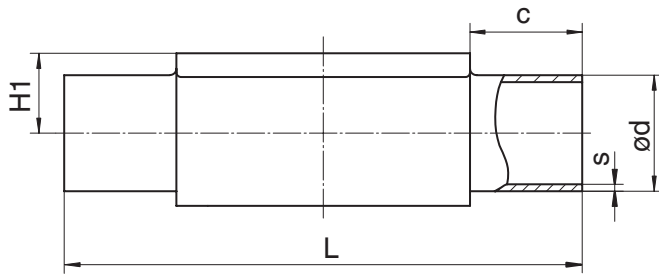

Connection type spigot DIN/EN/ISO (code 0, 16, 17, 18, 60)¹⁾, forged material (code 40, 42, F4)²⁾

MG	DN	NPS	c (min)	ød					H1	L	s				
				Connection type							Connection type				
				0	16	17	18	60			0	16	17	18	60
10	10	3/8"	25.0	-	12.0	13.0	14.0	17.2	12.5	108.0	-	1.0	1.5	2.0	1.6
	15	1/2"	25.0	18.0	18.0	19.0	20.0	21.3	12.5	108.0	1.5	1.0	1.5	2.0	1.6
25	15	1/2"	25.0	18.0	18.0	19.0	20.0	21.3	19.0	120.0	1.5	1.0	1.5	2.0	1.6
	20	3/4"	25.0	22.0	22.0	23.0	24.0	26.9	19.0	120.0	1.5	1.0	1.5	2.0	1.6
	25	1"	25.0	28.0	28.0	29.0	30.0	33.7	19.0	120.0	1.5	1.0	1.5	2.0	2.0
40	32	1 1/4"	25.0	34.0	34.0	35.0	36.0	42.4	26.0	153.0	1.5	1.0	1.5	2.0	2.0
	40	1 1/2"	25.0	40.0	40.0	41.0	42.0	48.3	26.0	153.0	1.5	1.0	1.5	2.0	2.0
50	50	2"	30.0	52.0	52.0	53.0	54.0	60.3	32.0	173.0	1.5	1.0	1.5	2.0	2.0
80	65	2 1/2"	30.0	-	-	70.0	-	76.1	62.0	216.0	-	-	2.0	-	2.0
	80	3"	30.0	-	-	85.0	-	88.9	62.0	254.0	-	-	2.0	-	2.3
100	100	4"	30.0	-	-	104.0	-	114.3	76.0	305.0	-	-	2.0	-	2.3

Dimensions in mm

MG = diaphragm size

1) Connection type

Code 0: Spigot DIN

Code 16: Spigot EN 10357 series B, formerly DIN 11850 series 1

Code 17: Spigot EN 10357 series A / DIN 11866 series A formerly DIN 11850 series 2

Code 18: Spigot DIN 11850 series 3

Code 60: Spigot ISO 1127/EN 10357 series C/DIN 11866 series B

2) Valve body material

Code 40: 1.4435 (F316L), forged body

Code 42: 1.4435 (BN2), forged body, Δ Fe < 0.5%

Code F4: 1.4539, forged body

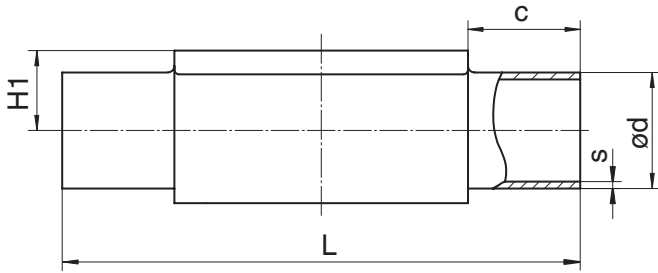

Connection type spigot DIN/EN/ISO (code 0, 17, 60)¹⁾, investment casting material (code C3)²⁾

MG	DN	NPS	c (min)	ød			H1	L	s		
				Connection type					Connection type		
				0	17	60			0	17	60
10	10	3/8"	25.0	-	13.0	17.2	12.5	108.0	-	1.5	1.6
	15	1/2"	25.0	-	19.0	21.3	12.5	108.0	-	1.5	1.6
25	15	1/2"	25.0	-	19.0	21.3	13.0	120.0	-	1.5	1.6
	20	3/4"	25.0	-	23.0	26.9	16.0	120.0	-	1.5	1.6
	25	1"	25.0	-	29.0	33.7	19.0	120.0	-	1.5	2.0
40	32	1¼"	25.0	-	35.0	42.4	24.0	153.0	-	1.5	2.0
	40	1½"	25.0	-	41.0	48.3	26.0	153.0	-	1.5	2.0
50	50	2"	30.0	-	53.0	60.3	32.0	173.0	-	1.5	2.0

Dimensions in mm

MG = diaphragm size

1) **Connection type**

Code 0: Spigot DIN

Code 17: Spigot EN 10357 series A / DIN 11866 series A formerly DIN 11850 series 2

Code 60: Spigot ISO 1127/EN 10357 series C/DIN 11866 series B

2) **Valve body material**

Code C3: 1.4435, investment casting

Spigot ASME/BS (code 55, 59, 63, 64, 65)

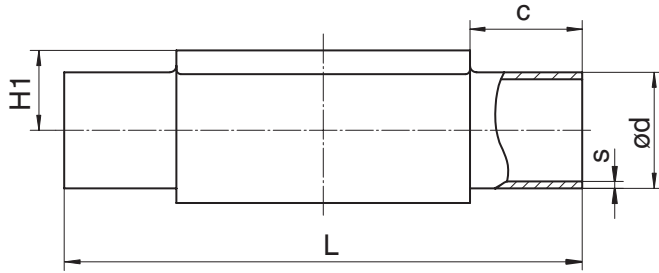

Connection type spigot ASME/BS (code 55, 59, 63, 64, 65)¹⁾, forged material (code 40, 42, F4)²⁾

MG	DN	NPS	c (min)	ød					H1	L	s				
				Connection type							Connection type				
				55	59	63	64	65			55	59	63	64	65
10	10	3/8"	25.0	9.53	9.53	17.1	-	17.1	12.5	108.0	1.2	0.89	1.65	-	2.31
	15	1/2"	25.0	12.70	12.70	21.3	21.3	21.3	12.5	108.0	1.2	1.65	2.11	1.65	2.77
	20	3/4"	25.0	19.05	19.05	-	-	-	12.5	108.0	1.2	1.65	-	-	-
25	15	1/2"	25.0	-	-	21.3	21.3	21.3	19.0	120.0	-	-	2.11	1.65	2.77
	20	3/4"	25.0	19.05	19.05	26.7	26.7	26.7	19.0	120.0	1.2	1.65	2.11	1.65	2.87
	25	1"	25.0	-	25.40	33.4	33.4	33.4	19.0	120.0	-	1.65	2.77	1.65	3.38
40	32	1 1/4"	25.0	-	-	42.2	42.2	42.2	26.0	153.0	-	-	2.77	1.65	3.56
	40	1 1/2"	25.0	-	38.10	48.3	48.3	48.3	26.0	153.0	-	1.65	2.77	1.65	3.68
50	50	2"	30.0	-	50.80	60.3	60.3	60.3	32.0	173.0	-	1.65	2.77	1.65	3.91
	65	2 1/2"	30.0	-	63.50	-	-	-	34.0	173.0	-	1.65	-	-	-
80	65	2 1/2"	30.0	-	63.50	73.0	73.0	73.0	62.0	216.0	-	1.65	3.05	2.11	5.16
	80	3"	30.0	-	76.20	88.9	88.9	88.9	62.0	254.0	-	1.65	3.05	2.11	5.49
100	100	4"	30.0	-	101.60	114.3	114.3	114.3	76.0	305.0	-	2.11	3.05	2.11	6.02

Dimensions in mm

MG = diaphragm size

1) **Connection type**

Code 55: Spigot BS 4825, part 1

Code 59: Spigot ASME BPE/DIN 11866 series C

Code 63: Spigot ANSI/ASME B36.19M schedule 10s

Code 64: Spigot ANSI/ASME B36.19M schedule 5s

Code 65: Spigot ANSI/ASME B36.19M schedule 40s

2) **Valve body material**

Code 40: 1.4435 (F316L), forged body

Code 42: 1.4435 (BN2), forged body, Δ Fe < 0.5%

Code F4: 1.4539, forged body

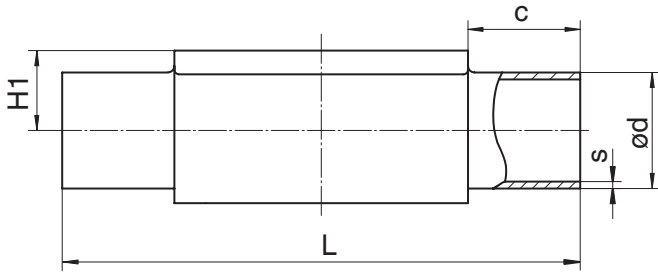

Connection type spigot ASME BPE (code 59)¹⁾, investment casting material (code C3)²⁾

MG	DN	NPS	c (min)	ød	H1	L	s
10	20	3/4"	25.0	19.05	12.5	108.0	1.65
25	20	3/4"	25.0	19.05	16.0	120.0	1.65
	25	1"	25.0	25.40	19.0	120.0	1.65
40	40	1½"	25.0	38.10	26.0	153.0	1.65
50	50	2"	30.0	50.80	32.0	173.0	1.65

Dimensions in mm

MG = diaphragm size

1) **Connection type**

Code 59: Spigot ASME BPE/DIN 11866 series C

2) **Valve body material**

Code C3: 1.4435, investment casting

Spigot JIS/SMS (code 35, 36, 37)

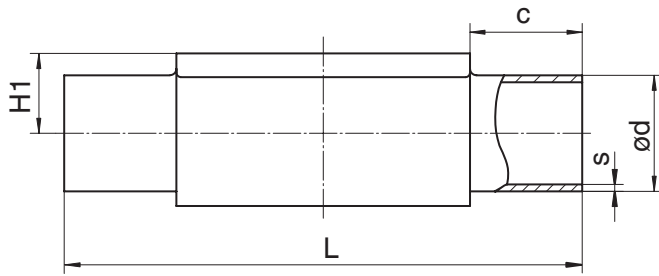

Connection type spigot JIS/SMS (code 35, 36, 37)¹⁾, forged material (code 40, 42, F4)²⁾

MG	DN	NPS	c (min)	ød			H1	L	s		
				Connection type					Connection type		
				35	36	37			35	36	37
10	10	3/8"	25.0	-	17.3	-	12.5	108.0	-	1.65	-
	15	1/2"	25.0	-	21.7	-	12.5	108.0	-	2.10	-
25	15	1/2"	25.0	-	21.7	-	19.0	120.0	-	2.10	-
	20	3/4"	25.0	-	27.2	-	19.0	120.0	-	2.10	-
	25	1"	25.0	25.4	34.0	25.0	19.0	120.0	1.2	2.80	1.2
40	32	1¼"	25.0	31.8	42.7	33.7	26.0	153.0	1.2	2.80	1.2
	40	1½"	25.0	38.1	48.6	38.0	26.0	153.0	1.2	2.80	1.2
50	50	2"	30.0	50.8	60.5	51.0	32.0	173.0	1.5	2.80	1.2
	65	2½"	30.0	63.5	-	63.5	34.0	173.0	2.0	-	1.6
80	65	2½"	30.0	63.5	76.3	63.5	62.0	216.0	2.0	3.00	1.6
	80	3"	30.0	76.3	89.1	76.1	62.0	254.0	2.0	3.00	1.6
100	100	4"	30.0	101.6	114.3	101.6	76.0	305.0	2.0	3.00	2.0

Connection type spigot SMS (code 37)¹⁾, investment casting material (code C3)²⁾

MG	DN	NPS	c (min)	ød	H1	L	s
25	25	1"	25.0	25.0	19.0	120.0	1.2
40	40	1½"	25.0	38.0	26.0	153.0	1.2
50	50	2"	30.0	51.0	32.0	173.0	1.2

Dimensions in mm

MG = diaphragm size

1) Connection type

Code 35: Spigot JIS-G 3447

Code 36: Spigot JIS-G 3459 schedule 10s

Code 37: Spigot SMS 3008

2) Valve body material

Code 40: 1.4435 (F316L), forged body

Code 42: 1.4435 (BN2), forged body, Δ Fe < 0.5%

Code C3: 1.4435, investment casting

Code F4: 1.4539, forged body

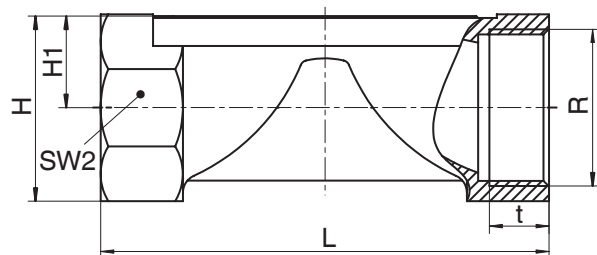
Threaded socket DIN (code 1)**Connection type threaded socket (code 1)¹⁾, investment casting material (code 37)²⁾**

MG	DN	NPS	H	H1	L	n	R	SW 2	t
10	12	3/8"	25.0	13.0	55.0	2	G 3/8	22.0	12.0
	15	1/2"	30.0	15.0	68.0	2	G 1/2	27.0	15.0
25	15	1/2"	28.3	14.8	85.0	6	G 1/2	27.0	15.0
	20	3/4"	33.3	17.3	85.0	6	G 3/4	32.0	16.0
	25	1"	42.3	21.8	110.0	6	G 1	41.0	13.0
40	32	1 1/4"	51.3	26.3	120.0	8	G 1 1/4	50.0	20.0
	40	1 1/2"	56.3	28.8	140.0	8	G 1 1/2	55.0	18.0
50	50	2"	71.3	36.0	165.0	8	G 2	70.0	26.0

Dimensions in mm

MG = diaphragm size

n = number of flats

1) Connection type

Code 1: Threaded socket DIN ISO 228

2) Valve body material

Code 37: 1.4408, investment casting

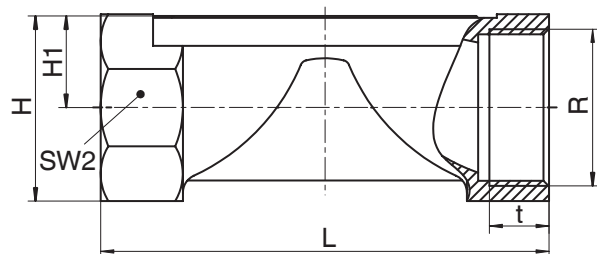
Threaded socket NPT (code 31)**Connection type threaded socket NPT (code 31)¹⁾, investment casting material (code 37)²⁾**

MG	DN	NPS	H	H1	L	n	R	SW 2	t
25	15	1/2"	28.3	14.8	85.0	6	NPT 1/2	27.0	14.0
	20	3/4"	33.3	17.3	85.0	6	NPT 3/4	32.0	14.0
	25	1"	42.3	21.8	110.0	6	NPT 1	41.0	17.0
40	32	1 1/4"	51.3	26.3	120.0	8	NPT 1 1/4	50.0	17.0
	40	1 1/2"	56.3	28.8	140.0	8	NPT 1 1/2	55.0	17.0
50	50	2"	71.3	36.3	165.0	8	NPT 2	70.0	18.0

Dimensions in mm

MG = diaphragm size

n = number of flats

1) Connection type

Code 31: NPT female thread

2) Valve body material

Code 37: 1.4408, investment casting

Threaded spigot DIN (code 6)

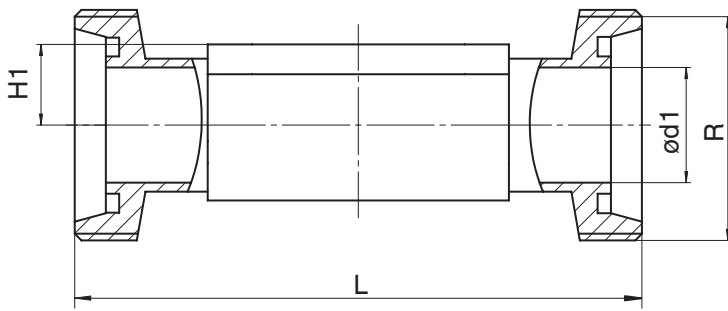

Connection type threaded spigot DIN (code 6)¹⁾, forged material (code 40, 42)²⁾

MG	DN	NPS	ød1	H1	L	R
10	10	3/8"	10.0	12.5	118.0	Rd 28 x 1/8
	15	1/2"	16.0	12.5	118.0	Rd 34 x 1/8
25	15	1/2"	16.0	19.0	118.0	Rd 34 x 1/8
	20	3/4"	20.0	19.0	118.0	Rd 44 x 1/6
	25	1"	26.0	19.0	128.0	Rd 52 x 1/6
40	32	1¼"	32.0	26.0	147.0	Rd 58 x 1/6
	40	1½"	38.0	26.0	160.0	Rd 65 x 1/6
50	50	2"	50.0	32.0	191.0	Rd 78 x 1/6
80	65	2½"	66.0	62.0	246.0	Rd 95 x 1/6
	80	3"	81.0	62.0	256.0	Rd 110 x 1/4

Dimensions in mm

MG = diaphragm size

1) Connection type

Code 6: Threaded spigot DIN 11851

2) Valve body material

Code 40: 1.4435 (F316L), forged body

Code 42: 1.4435 (BN2), forged body, Δ Fe < 0.5%

Cone spigot DIN (code 6K)

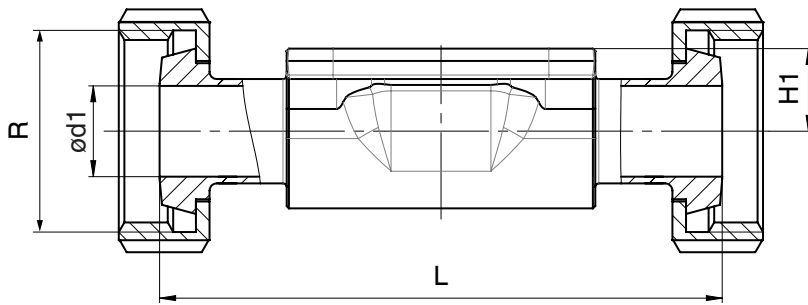

Connection type cone spigot DIN (code 6K) ¹⁾, forged material (code 40, 42) ²⁾

MG	DN	NPS	ød1	H1	L	R
10	10	3/8"	10.0	12.5	116.0	Rd 28 x 1/8
	15	1/2"	16.0	12.5	116.0	Rd 34 x 1/8
25	15	1/2"	16.0	19.0	116.0	Rd 34 x 1/8
	20	3/4"	20.0	19.0	114.0	Rd 44 x 1/6
	25	1"	26.0	19.0	127.0	Rd 52 x 1/6
40	32	1¼"	32.0	26.0	147.0	Rd 58 x 1/6
	40	1½"	38.0	26.0	160.0	Rd 65 x 1/6
50	50	2"	50.0	32.0	191.0	Rd 78 x 1/6
80	65	2½"	66.0	62.0	246.0	Rd 95 x 1/6
	80	3"	81.0	62.0	256.0	Rd 110 x 1/4

Dimensions in mm

MG = diaphragm size

1) Connection type

Code 6K: Cone spigot and union nut DIN 11851

2) Valve body material

Code 40: 1.4435 (F316L), forged body

Code 42: 1.4435 (BN2), forged body, Δ Fe < 0.5%

Flange EN (code 8)

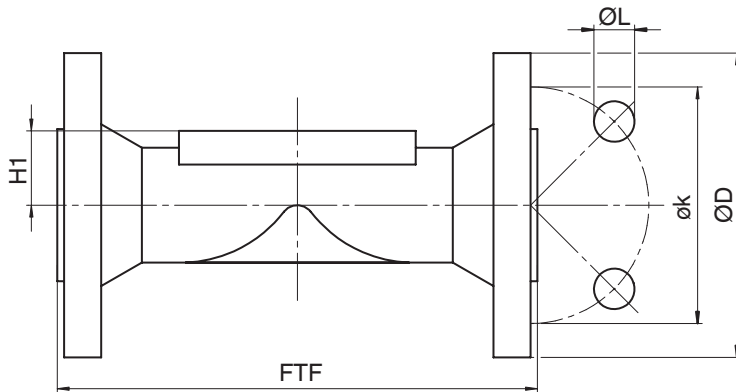

Connection type flange, length EN 558 (code 8)¹⁾, SG iron material (code 17, 18, 83), investment casting material (code 39, C3), forged material (code 40, 42)²⁾

MG	DN	NPS	øD	FTF			H1			øk	øL	n
				Material			Material					
				17, 18, 39, 83	C3	40, 42	17, 18, 39, 83	C3	40, 42			
25	15	1/2"	95.0	130.0	150.0	130.0	18.0	13.0	19.0	65.0	14.0	4
	20	3/4"	105.0	150.0	150.0	150.0	20.5	16.0	19.0	75.0	14.0	4
	25	1"	115.0	160.0	160.0	160.0	23.0	19.0	19.0	85.0	14.0	4
40	32	1 1/4"	140.0	180.0	180.0	180.0	28.7	24.0	26.0	100.0	19.0	4
	40	1 1/2"	150.0	200.0	200.0	200.0	33.0	26.0	26.0	110.0	19.0	4
50	50	2"	165.0	230.0	230.0	230.0	39.0	32.0	32.0	125.0	19.0	4
80	65	2 1/2"	185.0	-	-	290.0	-	-	62.0	145.0	19.0	4
	80	3"	200.0	310.0	-	310.0	59.5	-	62.0	160.0	19.0	8
100	100	4"	220.0	350.0	-	350.0	73.0	-	76.0	180.0	19.0	8

Dimensions in mm

MG = diaphragm size

n = number of bolts

1) **Connection type**

Code 8: Flange EN 1092, PN 16, form B, face-to-face dimension FTF EN 558 series 1, ISO 5752, basic series 1, length only for body configuration D

2) **Valve body material**

Code 17: EN-GJS-400-18-LT (GGG 40.3), PFA lined

Code 18: EN-GJS-400-18-LT (GGG 40.3), PP lined

Code 39: 1.4408, PFA lined

Code 40: 1.4435 (F316L), forged body

Code 42: 1.4435 (BN2), forged body, Δ Fe < 0.5%

Code 83: EN-GJS-400-18-LT (GGG 40.3), hard rubber lined

Code C3: 1.4435, investment casting

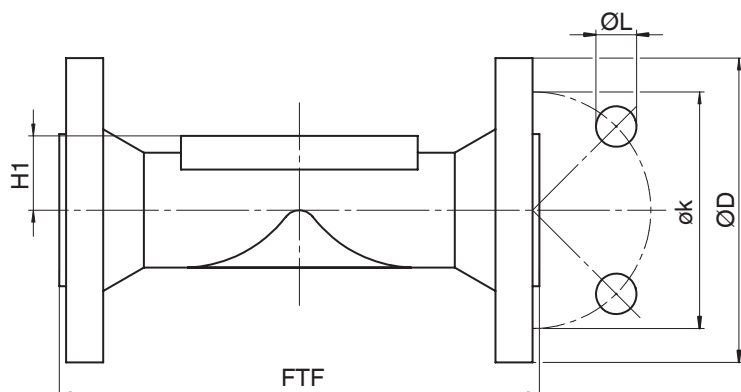
Flange ANSI Class (code 38, 39)

Connection type flange, length MSS SP-88 (code 38)¹⁾, SG iron material (code 17, 18, 83), investment casting material (code 39)²⁾

MG	DN	NPS	øD	FTF		H1	øk	øL	n
				Material					
				17, 18, 39	83				
25	20	3/4"	100.0	146.0	146.4	20.5	69.9	15.9	4
	25	1"	110.0	146.0	146.4	23.0	79.4	15.9	4
40	40	1½"	125.0	175.0	171.4	33.0	98.4	15.9	4
50	50	2"	150.0	200.0	197.4	39.0	120.7	19.0	4
80	80	3"	190.0	260.0	260.4	59.5	152.4	19.0	4
100	100	4"	230.0	327.0	324.4	73.0	190.5	19.0	8

Dimensions in mm

MG = diaphragm size

n = number of bolts

1) **Connection type**

Code 38: Flange ANSI Class 150 RF, face-to-face dimension FTF MSS SP-88, length only for body configuration D

2) **Valve body material**

Code 17: EN-GJS-400-18-LT (GGG 40.3), PFA lined

Code 18: EN-GJS-400-18-LT (GGG 40.3), PP lined

Code 39: 1.4408, PFA lined

Code 83: EN-GJS-400-18-LT (GGG 40.3), hard rubber lined

Dimensions

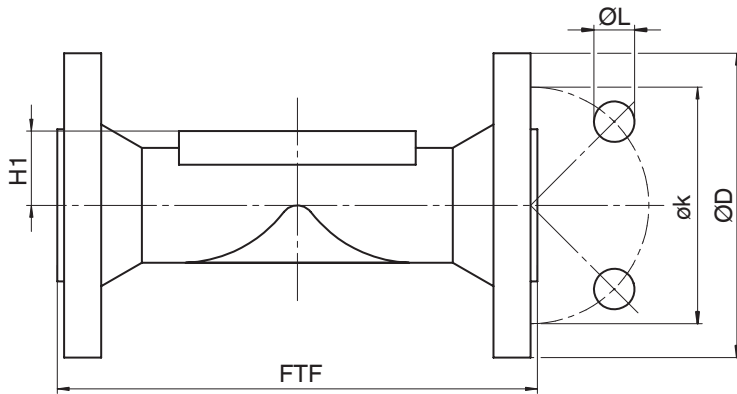

Connection type flange, length EN 558 (code 39)¹⁾, SG iron material (code 17, 18, 83), investment casting material (code 39, C3), forged material (code 40, 42)²⁾

MG	DN	NPS	øD	FTF			H1			øk	øL	n
				Material			Material					
				17, 18, 39, 83	C3	40, 42	17, 18, 39, 83	C3	40, 42			
25	15	1/2"	90.0	130.0	130.0	130.0	18.0	13.0	19.0	60.3	15.9	4
	20	3/4"	100.0	150.0	150.0	150.0	20.5	16.0	19.0	69.9	15.9	4
	25	1"	110.0	160.0	160.0	160.0	23.0	19.0	19.0	79.4	15.9	4
40	32	1 1/4"	115.0	180.0	180.0	180.0	28.7	24.0	26.0	88.9	15.9	4
	40	1 1/2"	125.0	200.0	200.0	200.0	33.0	26.0	26.0	98.4	15.9	4
50	50	2"	150.0	230.0	230.0	230.0	39.0	32.0	32.0	120.7	19.0	4
80	65	2 1/2"	180.0	-	-	290.0	-	-	62.0	139.7	19.0	4
	80	3"	190.0	310.0	-	310.0	59.5	-	62.0	152.4	19.0	4
100	100	4"	230.0	350.0	-	350.0	73.0	-	76.0	190.5	19.0	8

Dimensions in mm

MG = diaphragm size

n = number of bolts

1) Connection type

Code 39: Flange ANSI Class 125/150 RF, face-to-face dimension FTF EN 558 series 1, ISO 5752, basic series 1, length only for body configuration D

2) Valve body material

Code 17: EN-GJS-400-18-LT (GGG 40.3), PFA lined

Code 18: EN-GJS-400-18-LT (GGG 40.3), PP lined

Code 39: 1.4408, PFA lined

Code 40: 1.4435 (F316L), forged body

Code 42: 1.4435 (BN2), forged body, Δ Fe < 0.5%

Code 83: EN-GJS-400-18-LT (GGG 40.3), hard rubber lined

Code C3: 1.4435, investment casting

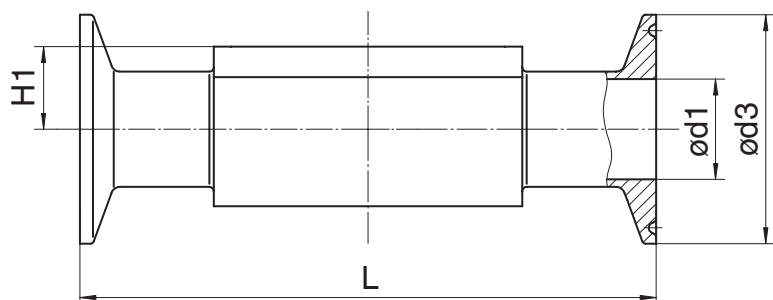
Clamp (code 80, 82, 88, 8A, 8E, 8P, 8T)**Connection type clamp DIN/ASME (code 80, 88, 8P, 8T)¹⁾, forged material (code 40, 42, F4)²⁾**

MG	DN	NPS	ød1		ød3		H1	L	
			Connection type		Connection type			Connection type	
			80, 8P	88, 8T	80, 8P	88, 8T		80, 8P	88, 8T
10	15	1/2"	9.40	9.40	25.0	25.0	12.5	88.9	108.0
	20	3/4"	15.75	15.75	25.0	25.0	12.5	101.6	117.0
25	20	3/4"	15.75	15.75	25.0	25.0	19.0	101.6	117.0
	25	1"	22.10	22.10	50.5	50.5	19.0	114.3	127.0
40	40	1½"	34.80	34.80	50.5	50.5	26.0	139.7	159.0
50	50	2"	47.50	47.50	64.0	64.0	32.0	158.8	190.0
	65	2½"	60.20	60.20	77.5	77.5	34.0	193.8	216.0
80	65	2½"	60.20	60.20	77.5	77.5	62.0	193.8	216.0
	80	3"	72.90	72.90	91.0	91.0	62.0	222.3	254.0
100	100	4"	97.38	97.38	119.0	119.0	76.0	292.1	305.0

Dimensions in mm

MG = diaphragm size

1) Connection type

Code 80: Clamp ASME BPE, face-to-face dimension FTF ASME BPE, length only for body configuration D

Code 88: Clamp ASME BPE, for pipe ASME BPE, face-to-face dimension FTF EN 558 series 7, length only for body configuration D

Code 8P: Clamp DIN 32676 series C, face-to-face dimension FTF ASME BPE, length only for body configuration D

Code 8T: Clamp DIN 32676 series C, face-to-face dimension FTF EN 558 series 7, length only for body configuration D

2) Valve body material

Code 40: 1.4435 (F316L), forged body

Code 42: 1.4435 (BN2), forged body, Δ Fe < 0.5%

Code F4: 1.4539, forged body

Dimensions

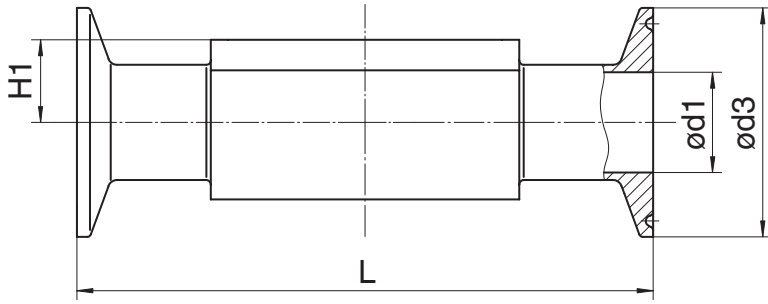

Connection type clamp DIN/ISO (code 82, 8A, 8E)¹⁾, forged material (code 40, 42, F4)²⁾

MG	DN	NPS	ød1			ød3			H1	L		
			Connection type			Connection type				Connection type		
			82	8A	8E	82	8A	8E		82	8A	8E
10	10	3/8"	14.0	10.0	-	25.0	34.0	-	12.5	108.0	108.0	-
	15	1/2"	18.1	16.0	-	50.5	34.0	-	12.5	108.0	108.0	-
25	15	1/2"	18.1	16.0	-	50.5	34.0	-	19.0	108.0	108.0	-
	20	3/4"	23.7	20.0	-	50.5	34.0	-	19.0	117.0	117.0	-
	25	1"	29.7	26.0	22.6	50.5	50.5	50.5	19.0	127.0	127.0	127.0
40	32	1¼"	38.4	32.0	31.3	64.0	50.5	50.5	26.0	146.0	146.0	146.0
	40	1½"	44.3	38.0	35.6	64.0	50.5	50.5	26.0	159.0	159.0	159.0
50	50	2"	56.3	50.0	48.6	77.5	64.0	64.0	32.0	190.0	190.0	190.0
	65	2½"	-	-	60.3	-	-	77.5	34.0	-	-	216.0
80	65	2½"	72.1	66.0	60.3	91.0	91.0	77.5	62.0	216.0	216.0	216.0
	80	3"	84.3	81.0	72.9	106.0	106.0	91.0	62.0	254.0	254.0	254.0
100	100	4"	109.7	100.0	97.6	130.0	119.0	119.0	76.0	305.0	305.0	305.0

Dimensions in mm

MG = diaphragm size

1) Connection type

Code 82: Clamp DIN 32676 series B, face-to-face dimension FTF EN 558 series 7, length only for body configuration D

Code 8A: Clamp DIN 32676 series A, face-to-face dimension FTF acc. to EN 558 series 7, length only for body configuration D

Code 8E: Clamp ISO 2852 for pipe ISO 2037, clamp SMS 3017 for pipe SMS 3008 face-to-face dimension FTF EN 558 series 7, length only for body configuration D

2) Valve body material

Code 40: 1.4435 (F316L), forged body

Code 42: 1.4435 (BN2), forged body, Δ Fe < 0.5%

Code F4: 1.4539, forged body



GEMÜ Gebr. Müller Apparatebau GmbH & Co. KG
Fritz-Müller-Straße 6-8, 74653 Ingelfingen-Criesbach, Germany
Phone +49 (0) 7940 1230 · info@gemue.de
www.gemu-group.com